

# Clearlight®

Infrared Saunas and Wellness Solutions

## **RED LIGHT THERAPY** THE CORE TOWER

**USER MANUAL**

# Contents

01. Welcome to <b>RED LIGHT THERAPY</b> .....	2
02. Components .....	4
03. Safety Precautions.....	5
04. Assembly Instructions.....	7
05. Operating your Red Light Therapy .....	10
06. Specifications .....	11
07. Usage.....	12
08. Storage When Not In Use .....	14
09. Warranty .....	14
10. Contact Information .....	16

# 1. Welcome to RED LIGHT THERAPY

Red Light Therapy, also known as photobiomodulation and low-level light therapy, utilizes specific red wavelengths of light to provide a range of health and wellness benefits. Scientists initially explored this therapy to help plants grow in space and unexpectedly discovered that intense red LED light also enhanced the growth of human cells.

This revelation led to the investigation of red and near infrared wavelengths on human cells, revealing their ability to increase energy production inside our cells. Clearlight Red Light Therapy taps into the power of red and near infrared light to boost energy production in our cells, offering various benefits for our health and well-being.

## **The Clearlight Difference**

Clearlight® has been a pioneer in Infrared Saunas, providing high-quality infrared therapy for over 25 years. We expanded our expertise to include light therapy inside our infrared saunas about 15 years ago, and now, we have integrated the same advanced technology into our stand-alone Clearlight Light Therapy® Tower. Our Red Light Therapy utilizes powerful medical-grade LED light bulbs to deliver optimal wavelengths to your body, offering exceptional health and wellness benefits.

At Clearlight, we've reimagined the way healing efficiency is achieved with our exclusive Variable Optics™ technology. Unlike competitor products that rely on a single optical output at 30°, our innovative Light Therapy Tower incorporates multiple angles for the light waves to deeply penetrate your cells.

This intelligent design allows for greater light absorption by the skin, delivering more benefits in less time with each session.

# 1. Welcome to RED LIGHT THERAPY - Continued

With our Variable Optics™, you receive precise, pin-pointed light for targeted therapy on specific areas and gentle, diffuse light for comprehensive whole-body treatment. It's a transformative approach to healing that ensures you get the most out of every session.

Our scientifically formulated red lights incorporate proven technology, providing you with a reliable and effective solution tailored to the needs of your body. With a light output intensity rating of 100 MW/cm<sup>2</sup> ensuring that you receive the optimal wavelengths in every session for effective results.

## A. Clearlight Red Light Therapy | The CORE Tower

Standing at 38" tall, The CORE tower can be easily attached to our stand or placed inside your Clearlight Infrared Sauna. Designed to target the center or CORE of your body, it delivers powerful red light therapy for exceptional results. Enhance your well-being and unlock the healing potential within you with the Clearlight The CORE Tower.

## 2. Components

- 1 The CORE Tower
- 2 Dust Bag for Storage
- 3 Goggles
- 4 Wall Adapter
- 5 Sauna Door Mount Plugs

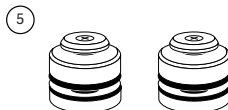
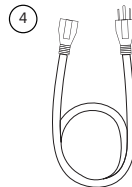
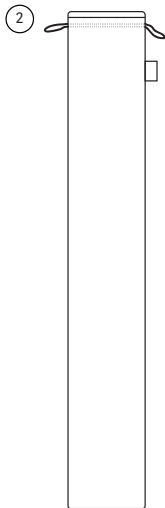
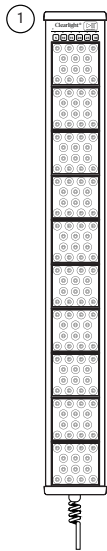

### 3. Safety Precautions



NOTE: PLEASE READ BEFORE USING YOUR CLEARLIGHT RED LIGHT THERAPY CORE TOWER

- Do not touch metal parts when running inside a hot sauna.
- Do not remove from sauna door until fixture is cooled down.
- Do not use near water or immerse the unit in water.
- Do not if the power cord is damaged.
- Do not touch the unit with wet hands.
- Do not use near flammable or combustible products.
- Do not use the unit while sleeping.
- Do not modify or try to repair the unit.
- Do not use outdoors.
- Do not use this unit on infants.
- Do not allow children to use this unsupervised.
- Do not use unapproved power supply cords.
- Do not wash the unit with heavy water – a light damp cloth / dust only.
- Do not use the device if it has been damaged.
- Do not continue use of the CORE Tower if you have any adverse reaction

## 3. Safety Precautions- Continued

- Do not hesitate to call us with questions regarding the set-up, cleaning or maintenance of the unit.

### Important Safeguards

- **EYE PROTECTION** - special eye protection is not necessary. Clearlight Red Light Therapy can be used without eye protection, and standard sunglasses provide adequate protection. We include optional goggles with our products for added comfort during the adjustment period.
- **CLOTHING** - You may wear clothes, if desired however, the areas being treated should be fully exposed to the light with no obstructions.
- **CREAMS OR LOTIONS** - It is best not to use creams or lotions right before a treatment as it forms a barrier and prevents you from getting the full effect of the therapy. It also might irritate the skin.
- **MEDICATIONS** - There are some medications which interact with Light Therapy. Some drugs cause photosensitivity, so it is always best to check with your physician before using the tower if you are taking medications.
- **CHILDREN AND ELDERLY** - Clinical studies are constantly showing how Light Therapy can be safe and beneficial for everyone. However, if you have any doubts or concerns, we recommend checking with your healthcare provider.

## 4. Assembly Instructions

Clearlight Red Light Therapy | The CORE Tower can be used without a stand. It can be conveniently mounted inside any of our Clearlight saunas or you can place it against a wall or even on its side for flexible usage options.

### Adding the CORE Tower to your Sauna:

Our exclusive CORE Tower is specifically designed to take your Clearlight Sauna experience to new heights of rejuvenation.

## 4. Assembly Instructions - Continued

Crafted to withstand sauna heat, the CORE seamlessly attaches to your Clearlight Sauna door, combining Red Light Therapy with Infrared Sauna sessions for unmatched benefits.

### A. Installing the Sauna Door Mounting Pins:

1. Remove existing metal bolts from the sauna door. Keep them for potential future options.  
(Make sure that door hinges are fully tightened, as they can loosen over time due to use.)
2. Insert black plastic washers over exterior and interior door mounts.
3. Insert male door mount through top glass hole, align with female door mount.
4. Insert and snugly tighten screw on the inside door mount.
5. Repeat for the second hole. Place name plates on exterior mounts.

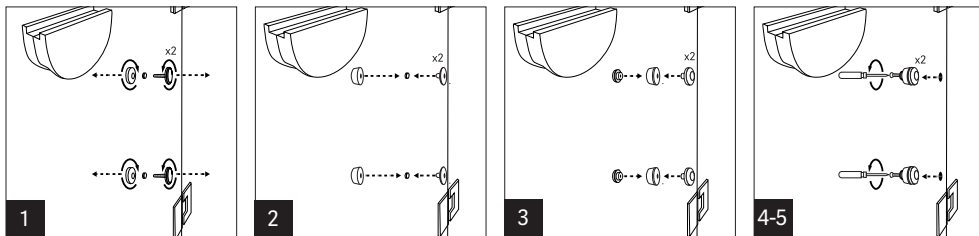

### B. Attaching Light Therapy Tower:

1. Stabilize the sauna door.
2. Align fixture with mounting pins using glass reflection.
3. Slide fixture down over pins until engaged in back plate.

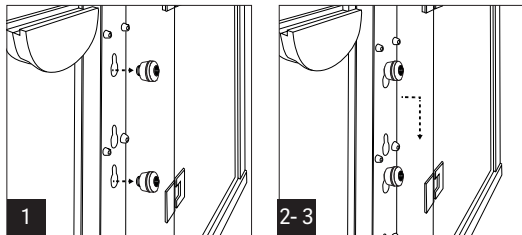

## 4. Assembly Instructions - Continued

### Removal and Height Adjustment:

1. Grip fixture center, move upward to release from pins.
2. Adjust height or remove the Tower.

### Plugging in the Tower:

The plug is specially designed to be used in your Clearlight Sauna. Plug the tower into the available plug inside your sauna. It will either be located on the floor near the front of your sauna or on the inside front wall of the sauna.

\*When using The CORE Tower in your Clearlight Sauna, please refer to our sauna conversion chart to see if your saunas electrical requirements need to be updated to accommodate the Core Red Light Therapy tower.

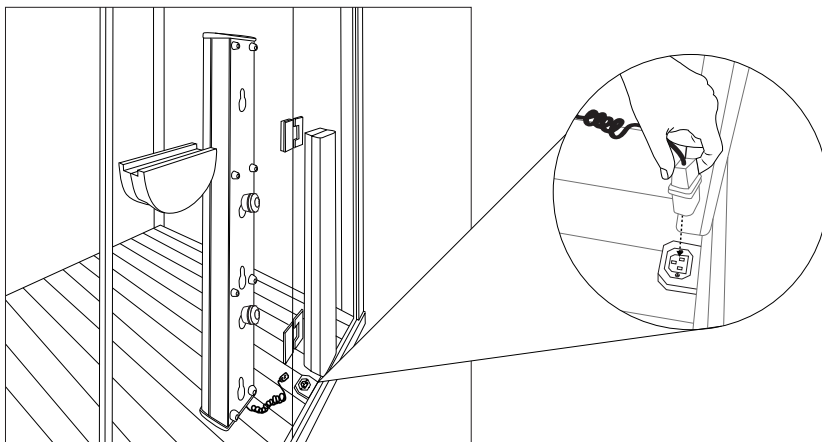

## 4. Assembly Instructions - Continued

### C. For Residential Applications: Activating the Power Outlet on Your Sauna Model

If your sauna keypad features an AUX button, please follow these steps:

1. Plug the tower into the available plug inside your sauna, typically located on the floor near the sauna's front or on the inside front wall.
2. Power on the sauna.
3. Change the temperature display to Celsius by using the F/C button.
4. Set the temperature to 50 degrees Celsius.
5. Press and hold the AUX button for 5 seconds.
6. The outlet will now remain permanently on.

If your sauna keypad does not have an AUX button, please follow these steps:

1. Plug the tower into the available plug inside your sauna, typically located on the floor near the sauna's front or on the inside front wall
2. Power on the sauna.
3. Simultaneously press and hold the Temp Up and Time Up buttons for 5 seconds.
4. The floor plug is now activated, and you can turn on the light therapy tower.

### D. How to activate power for sauna (Commercial Applications):

Please note that this operation activates the outlet for a single 30-minute session and needs to be repeated each time you want to use the Red Light.

If your sauna keypad has an AUX button on it, please follow these steps:

1. Plug the tower into the available plug inside your sauna, typically located on the floor near the sauna's front or on the inside front wall.
2. Power on the sauna.
3. Change the temperature display to Celsius using the F/C button.
4. Set the temperature to 40 degrees Celsius
5. Hold the AUX button for 10 seconds.
6. The floor plug is now activated, and you can turn on the light therapy tower for your 30-min session.

E. If you would like to use the Core Tower outside of the sauna, we have included a wall adapter to connect to the attached cable. We offer a stand, along with other additional mounting options that are available for purchase

## 5. Operating

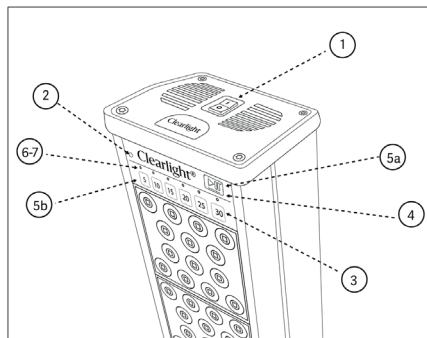

1. Turn on the main power switch on the top.
2. Front panel lights up with a small red light when powered on.
3. Choose session duration with one touch from 5 to 30 minutes.
4. Pause by pressing the Play/Pause button, resume by pressing again.
5. To reset timer:
  - A. Hold the Play/Pause button for 2-3 seconds for standby.
  - B. Press the desired time button for a specific reset.
6. LED countdown shows therapy time in 5-minute increments.
7. Last 4 minutes, LED flashes for the remaining time.

**For Visually Impaired:**  
Tactile switches and Braille on controls.

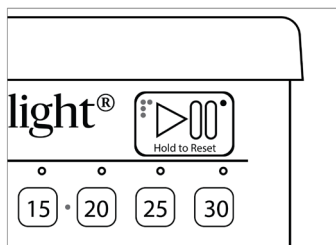

**Automated Home System Integration:**  
Hold 5 and 30 buttons, press Play/Pause for timer override.

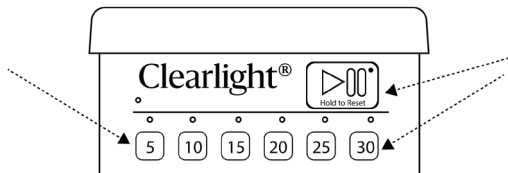

**Fan Operation:**  
After turning off, the fan may run up to 5 minutes for cooling.

## 6. Specifications

Unit Dimensions: 5" W x 4" D x 38" H

Unit Weight: 14.6 lbs

Power: 100-240v AC, 50-60hz, 200W

The Clearlight CORE Tower is proudly FDA registered, demonstrating our commitment to quality, safety, and regulatory compliance"



### How to add to your sauna - Electrical Requirements:

Elevate your Clearlight® Infrared Sauna experience by adding Clearlight Red Light Therapy | The CORE Tower to your sauna door. Please note that depending on your specific sauna model, you may need to update your electrical requirements to accommodate The CORE Tower. For assistance with ordering the correct cord or any additional information, we recommend contacting one of our Sauna Specialists.

Sauna Model	Voltage Change	Electrical Circuit
Sanctuary 1	from 120v/15Amp to 120v/20Amp	required NEMA 5-20p
Sanctuary 2	from 120v/20Amp to 120v/30Amp	required NEMA 5-30p
Sanctuary C	from 240v/15Amp to 240v/20Amp	required NEMA 6-20p
Sanctuary Y	from 240v/15Amp to 240v/20Amp	required NEMA 6-20p
Premier IS-2	from 120v/15Amp to 120v/20Amp	required NEMA 5-20p
Premier IS-C	from 120v/15Amp to 120v/30Amp	required NEMA 5-30p

## 7. Usage

### Using Your Clearlight Light Therapy Tower:

When using your Clearlight Light Therapy Tower, you want the clean skin of the targeted areas exposed directly to the light. The wavelengths of the lights cannot travel through clothing.

Incorporating red light therapy into your daily routine can bring remarkable benefits to your life. Choose a convenient spot, make it a regular practice, and experience the transformative power of red light therapy.

### Usage Guide: For General Health, Wellness, and Energy:

- A. When standing 6"-10" from the red light, we recommend a 15-20 min session. Our stand design ensures an ideal distance of 6 inches between you and the red light therapy tower. Simply align your feet with the base on the stand for optimal results.
- B. When sitting 12-18" away from the tower, we recommend a 20-30 min session. This distance allows for the rejuvenation of your cells over a broader area, promoting an overall feeling of wellness.

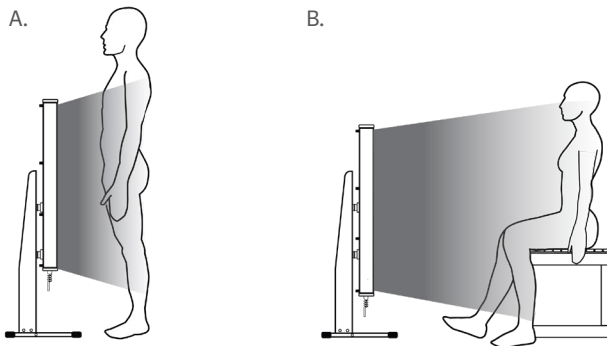

## 7. Usage - Continued

- Consistency is key in the beginning of your light therapy treatments. We recommend daily use, gradually tapering to three or four times per week as time progresses. For targeted areas with concentrated pain, exposure can be as frequent as 2 to 3 times per day.
- Spot treatment therapy focuses on specific body areas such as the back, arms, or joints. It is recommended to place the body part approximately 4 to 6 inches from the tower for 10-20 minutes per treatment.

Please note that there is no such thing as “too much” light therapy. However, after a certain point, your body will no longer absorb additional light or receive additional benefits

### Contraindications for Red Light Therapy:

- If you have a serious health issue or chronic illness, consult your doctor or pharmacist before starting Red Light Therapy to address any concerns or medication interactions.
- Red Light Therapy is generally safe and pain-free, with no severe side effects reported. However, some users have experienced minor side effects such as headaches, irritability, and eye strain.
- Consult your doctor if you have bipolar disorder, as rare cases of Red Light Therapy causing mania in bipolar patients have been reported.
- To avoid potential risks, protect your eyes during Red Light Therapy sessions and refrain from staring directly into the light.
- If you have photosensitivity conditions like lupus or are on medications that make you photosensitive, it's best to avoid red light therapy.
- Trust your instincts and if you notice any changes during Red light therapy speak to your doctor promptly to address any concerns. Your well-being is our top priority.

## 8. Storage When Not in Use

To ensure the longevity and performance of your **RED LIGHT THERAPY TOWER**, it's essential to store it unplugged properly when not in use. Keep the unit in a dry and secure location. Cover the tower with the provided dust bag for convenient storage.

**Cleaning and maintenance** - Occasional dusting with a light damp cloth is recommended with the unit unplugged.

## 9. Warranty

Your Clearlight Red Light Therapy | The CORE Tower is warranted to be free of defects in material and workmanship for:

Workmanship: 5 years for Residential use, 5 years for Commercial use

Electrical Components: 5 years for Residential use, 5 years for Commercial use

This warranty extends only to the original retail purchases of the Red Light and terminates upon transfer of ownership. To the original purchaser only, Sauna Works warrants the Clearlight Light Therapy Tower to be free of defects in materials, workmanship or design under normal use and service conditions for five years from the date of purchase.

If the product and/or equipment should become defective within the 5-year warranty period, Sauna Works will send replacement parts or replace it (at our discretion) free of charge, including return transportation to you. All labor is not included.

You **MUST** receive authorization before returning product to the factory, as Sauna Works will not accept collect shipments. Sauna Works reserves the right to repair or replace component parts without return of the entire unit.

This warranty does not include damage resulting from accident, abuse or misuse of the product and expressly excludes normal wearing of parts or defect caused by transportation, accident, fire, flood, improper assembly, alteration, or negligence.

## 9. Warranty- Continued

In addition, all representations and warranties made by any person or entity other than Sauna Works main office is excluded from this warranty.

**IMPLIED WARRANTIES, INCLUDING THOSE OF MERCHANTABILITY AND FITNESS FOR A PARTICULAR PURPOSE, ARE LIMITED TO FIVE YEARS FROM PURCHASE AND ALL IMPLIED WARRANTIES ARE EXPRESSLY EXCLUDED TO THE EXTENT PERMITTED BY LAW AND ARE OTHERWISE LIMITED TO THE TERMS OF EXPRESS WARRANTIES AS SET FORTH ABOVE.**

This is the exclusive remedy, and law for consequential or incidental damages under any and all warranties are excluded to the extent exclusion permits liability.

This warranty does not cover or compensate for any loss of use damages that may occur as a result of failure of equipment covered under this warranty.

Sauna Works reserves the right to alter or change equipment without prior notice, and to repair or replace warranted equipment with new parts or new products.

The Products should be installed only in applications where ambient temperatures do not exceed 145°F/63°C. Installation and use of the products in applications where ambient temperatures exceed 145°F/63°C will result in reduced life, lumen output.

For the purposes of being entitled to make a claim under this warranty, a decrease in lumen output of less than 70% under the L70 Standard or LED failure of less than fifteen percent (15%), shall not be considered a defect.

## 10. Contact Information

For your record, please complete the following information. You will need to refer to this information when calling Clearlight® customer service.

**Date of Purchase:**

**Date of Delivery:**

**Model Number:**

**Serial Number:**

**Dealer information (Name and Telephone number):**

# Clearlight®

Infrared Saunas and Wellness Solutions

## **RED LIGHT THERAPY** THE CORE TOWER

**USER MANUAL**