

# Clearlight®

Infrared Saunas and Wellness Solutions

## **RED LIGHT THERAPY** THE PERSONAL TOWER

**USER MANUAL**



# Contents

01. Welcome to <b>RED LIGHT THERAPY</b> .....	2
02. Components .....	4
03. Specifications .....	4
04. Safety Precautions. ....	5
05. Assembly Instructions .....	7
06. Operating your Red Light Therapy .....	9
07. Usage.....	10
08. Storage When Not In Use .....	12
09. Warranty .....	12
10. Contact Information .....	14

# 1. Welcome to RED LIGHT THERAPY

Red Light Therapy, also known as Photobiomodulation and low-level light therapy, utilizes specific red wavelengths of light to provide a range of health and wellness benefits. Scientists initially explored this therapy to help plants grow in space and unexpectedly discovered that intense red LED light also enhanced the growth of human cells.

This revelation led to the investigation of red and near infrared wavelengths on human cells, revealing their ability to increase energy production inside our cells. Clearlight Red Light Therapy taps into the power of red and near infrared light to boost energy production in our cells, offering various benefits for our health and well-being.

## **The Clearlight Difference**

Clearlight® has been a pioneer in Infrared Saunas, providing high-quality infrared therapy for over 25 years. We expanded our expertise to include light therapy inside our infrared saunas about 15 years ago, and now, we have integrated the same advanced technology into our stand-alone Clearlight Light Therapy® Towers. Our Red Light Therapy utilizes powerful medical-grade LED light bulbs to deliver optimal wavelengths to your body, offering exceptional health and wellness benefits.

At Clearlight, we've reimagined the way healing efficiency is achieved with our exclusive Variable Optics™ technology. Unlike competitor products that rely on a single optical output at 30°, our innovative Light Therapy Tower incorporates multiple angles for the light waves to deeply penetrate your cells.

This intelligent design allows for greater light absorption by the skin, delivering more benefits in less time with each session.

# 1. Welcome to RED LIGHT THERAPY - Continued

With our Variable Optics™, you receive precise, pin-pointed light for targeted therapy on specific areas and gentle, diffused light for comprehensive whole-body treatment. It's a transformative approach to healing that ensures you get the most out of every session.

Our scientifically formulated red lights incorporate proven technology, providing you with a reliable and effective solution tailored to the needs of your body. With a light output intensity rating of 100 MW/cm<sup>2</sup> ensuring that you receive the optimal wavelengths in every session for effective results.

## A. Clearlight Red Light Therapy | The PERSONAL Tower

The PERSONAL Tower is your personal gateway to targeted healing and rejuvenation. Compact and measuring 13 3/8" tall, this portable device can be conveniently placed on any tabletop or mounted on the included stand. Its versatile design allows you to focus on specific areas of your body, such as the face, hands, feet, arms, or any smaller area that requires spot treatment.

## 2. Components

- 1 The PERSONAL Tower
- 3 Goggles

- 2 PERSONAL Tower Stand
- 4 Dust Bag for Storage

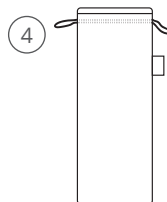
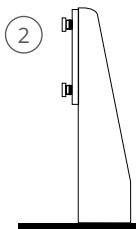
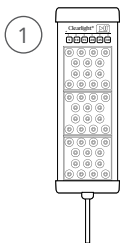

## 3. Specifications

Unit: 5" W x 3 1/2" D x 13 3/8" H

Unit Weight: 6 lbs

Stand: 5 3/4" W x 9" D x 12 1/2" H

Stand Weight: 2 lbs

Total Weight (Unit and Stand): 8 lbs

Power: 100-240v AC, 50-60hz, 60W

## 3. Specifications - Continued

The Clearlight PERSONAL Tower is proudly FDA registered, demonstrating our commitment to quality, safety, and regulatory compliance”



## 4. Safety Precautions



**NOTE: PLEASE READ BEFORE USING YOUR CLEARLIGHT RED LIGHT THERAPY TOWER**

- Do not use near water or immerse the unit in water.
- Do not if the power cord is damaged.
- Do not touch the unit with wet hands.
- Do not use near flammable or combustible products.
- Do not use the unit while sleeping.
- Do not modify or try to repair the unit.
- Do not use outdoors.
- Do not use this unit on infants.
- Do not allow children to use this unsupervised.
- Do not use unapproved power supply cords.

## 4. Safety Precautions- Continued

- Do not wash the unit with heavy water – Use a light damp cloth/dust only with the unit unplugged.
- Do not use the device if it has been damaged.
- Do not continue use of the PERSONAL Tower if you have any adverse reaction.
- Do not hesitate to call us with questions regarding the set-up, cleaning or maintenance of the unit.

### Important Safeguards

- **EYE PROTECTION** - special eye protection is not necessary. Clearlight Red Light Therapy can be used without eye protection, and standard sunglasses provide adequate protection. We include optional goggles with our products for added comfort during the adjustment period.
- **CLOTHING** - You may wear clothes, if desired however, the areas being treated should be fully exposed to the light with no obstructions.
- **CREAMS OR LOTIONS** - It is best not to use creams or lotions right before a treatment as it forms a barrier and prevents you from getting the full effect of the therapy. It also might irritate the skin.
- **MEDICATIONS** - There are some medications which interact with Light Therapy. Some drugs cause photo-sensitivity, so it is always best to check with your physician before using the tower if you are taking medications.
- **CHILDREN AND ELDERLY** - Clinical studies are constantly showing how Light Therapy can be safe and beneficial for everyone. However, if you have any doubts or concerns, we recommend checking with your healthcare provider.



# 5. Assembly Instructions

## Assembling the stand:

1. Attach the metal frame (a) to the base (b) using 4 screws (c).
2. Gather the polymer spacer (d), the stainless steel retainers (e) and the remaining screws and assemble as shown.
3. Once the screws are firmly tightened, apply the protective anti-scratch labels on the face of stainless steel retainers as fig. 2.

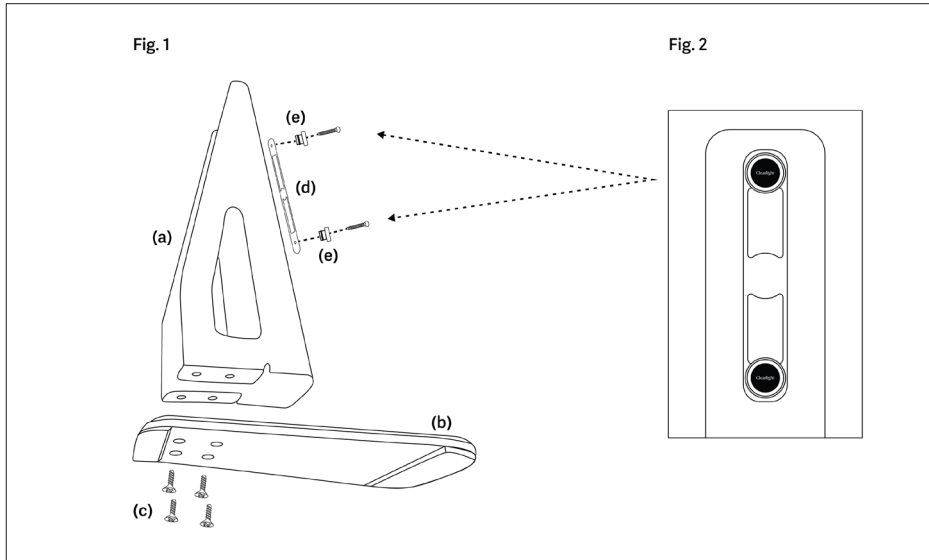

## 5. Assembly Instructions - Continued

Attaching the Red Light Tower to the stand:

1. Stabilize the stand.
2. Align fixture with mounting pins.
3. Slide fixture down over pins until engaged on back plate.

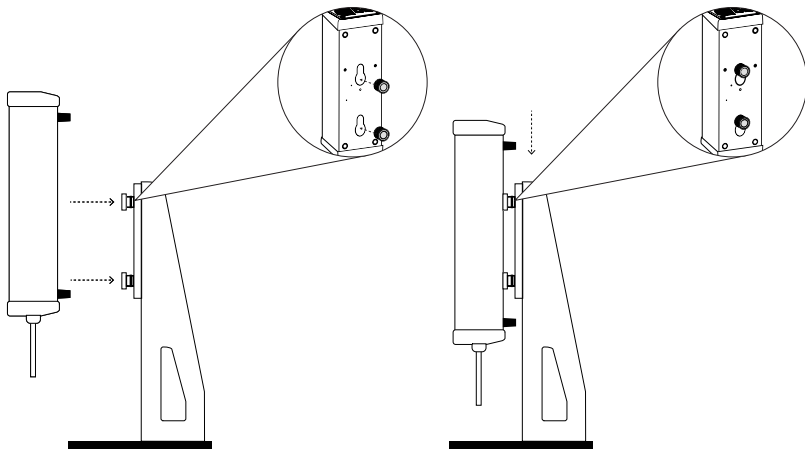

## 6. Operating

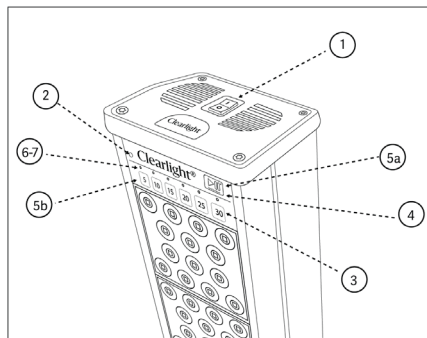

1. Turn on the main power switch on the top.
2. Front panel lights up with a small red light when powered on.
3. Choose session duration with one touch from 5 to 30 minutes.
4. Pause by pressing the Play-Pause button, resume by pressing again.
5. To reset timer:
  - a. Hold the Play/Pause button for 2-3 seconds for standby.
  - b. Press the desired time button for a specific reset.
6. LED countdown shows therapy time in 5-minute increments.
7. Last 4 minutes, LED flashes for the remaining time.

**For Visually Impaired:**  
Tactile switches and Braille on controls.

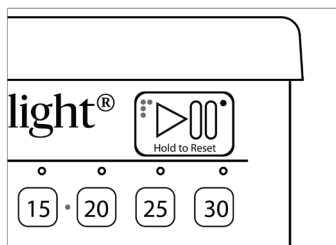

**Automated Home System Integration:**  
Hold 5 and 30 buttons, press Play/Pause for timer override.



**Fan Operation:**  
After turning off, the fan may run up to 5 minutes for cooling.

## 7. Usage

### Using Your Clearlight Light Therapy Tower:

When using your Clearlight Light Therapy Tower, you want the clean skin of the targeted areas exposed directly to the light. The wavelengths of the lights cannot travel through clothing.

Incorporating red light therapy into your daily routine can bring remarkable benefits to your life. Choose a convenient spot, make it a regular practice, and experience the transformative power of red light therapy.

### Usage Guide: For General Health, Wellness, and Energy:

- A. When standing 6"-10" from the red light, we recommend a 15-20 min session.
- B. When sitting 12-18" away from the tower, we recommend a 20-30 min session.  
This distance allows for the rejuvenation of your cells over a broader area, promoting an overall feeling of wellness.

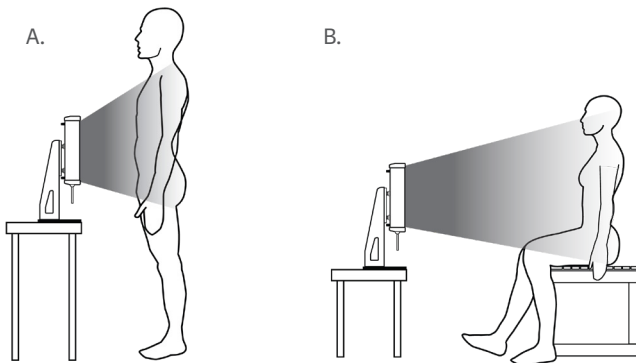

\*Also can be used for spot treatments

## 7. Usage - Continued

- This portable device can be easily positioned on a tabletop or secured using the provided stand. Its adaptable design enables you to target specific body areas like the face, hands, feet, arms, or any smaller region requiring focused treatment.
- Consistency is key in the beginning of your light therapy treatments. We recommend daily use, gradually tapering to three or four times per week as time progresses. For targeted areas with concentrated pain, exposure can be as frequent as 2 to 3 times per day.
- Spot treatment therapy focuses on specific body areas such as the back, arms, or joints. It is recommended to place the body part approximately 4 to 6 inches from the tower for 10-20 minutes per treatment.

Please note that there is no such thing as “too much” light therapy. However, after a certain point, your body will no longer absorb additional light or receive additional benefits

### **Contraindications for Red Light Therapy:**

- If you have a serious health issue or chronic illness, consult your doctor or pharmacist before starting Red Light Therapy to address any concerns or medication interactions.
- Red Light Therapy is generally safe and pain-free, with no severe side effects reported. However, some users have experienced minor side effects such as headaches, irritability, and eye strain.
- Consult your doctor if you have bipolar disorder, as rare cases of Red Light Therapy causing mania in bipolar patients have been reported.
- To avoid potential risks, protect your eyes during Red Light Therapy sessions and refrain from staring directly into the light.
- If you have photo-sensitivity conditions like lupus or are on medications that make you photosensitive, it's best to avoid red light therapy.
- Trust your instincts and if you notice any changes during Red light therapy speak to your doctor promptly to address any concerns. Your well-being is our top priority.

## 8. Storage When Not in Use

To ensure the longevity and performance of your **RED LIGHT THERAPY TOWER**, it's essential to store it unplugged properly when not in use. Keep the unit in a dry and secure location. Cover the tower with the provided dust bag for convenient storage.

**Cleaning and maintenance** - Occasional dusting with a light damp cloth is recommended with the unit unplugged.

## 9. Warranty

Your Clearlight Red Light Therapy | The PERSONAL Tower is warranted to be free of defects in material and workmanship for:

Workmanship: 5 years for Residential and Commercial

Electrical Components: 5 years for Residential and Commercial

This warranty extends only to the original retail purchases of the Red Light and terminates upon transfer of ownership. To the original purchaser only, Sauna Works warrants the Clearlight Red Light Therapy Tower to be free of defects in materials, workmanship or design under normal use and service conditions for five years from the date of purchase.

If the product and/or equipment should become defective within the 5-year warranty period, Sauna Works will send replacement parts or replace it (at our discretion) free of charge, including return transportation to you. All labor is not included.

You **MUST** receive authorization before returning product to the factory, as Sauna Works will **Not** accept collect shipments. Sauna Works reserves the right to repair or replace component parts without return of the entire unit.

This warranty does not include damage resulting from accident, abuse or misuse of the product and expressly excludes normal wearing of parts or defect caused by transportation, accident, fire, flood, improper assembly, alteration, or negligence.

## 9. Warranty- Continued

In addition, all representations and warranties made by any person or entity other than Sauna Works main office is excluded from this warranty.

**IMPLIED WARRANTIES, INCLUDING THOSE OF MERCHANTABILITY AND FITNESS FOR A PARTICULAR PURPOSE, ARE LIMITED TO FIVE YEARS FROM PURCHASE AND ALL IMPLIED WARRANTIES ARE EXPRESSLY EXCLUDED TO THE EXTENT PERMITTED BY LAW AND ARE OTHERWISE LIMITED TO THE TERMS OF EXPRESS WARRANTIES AS SET FORTH ABOVE.**

This is the exclusive remedy, and law for consequential or incidental damages under any and all Warranties are excluded to the extent exclusion permits liability.

This warranty does not cover or compensate for any loss of use damages that may occur as a result of failure of equipment covered under this warranty.

Sauna Works reserves the right to alter or change equipment without prior notice, and to repair or replace warranted equipment with new parts or new products.

The Products should be installed only in applications where ambient temperatures do not exceed 145°F/63°C. Installation and use of the products in applications where ambient temperatures exceed 145°F/63°C will result in reduced life, lumen output.

For the purposes of being entitled to make a claim under this warranty, a decrease in lumen output of less than 70% under the L70 Standard or LED failure of less than fifteen percent (15%), shall not be considered a defect.

## 10. Contact Information

For your record, please complete the following information. You will need to refer to this information when calling Clearlight® customer service.

**Date of Purchase:**

**Date of Delivery:**

**Model Number:**

**Serial Number:**

**Dealer information (Name and Telephone number):**





# Clearlight®

Infrared Saunas and Wellness Solutions

**RED LIGHT THERAPY**  
THE PERSONAL TOWER